

100-ALC

COMPUERTA DE REGULACIÓN CIRCULAR





SERIE ALR 100-ALC

COMPUERTA
DE REGULACIÓN
CIRCULAR



Modelo 100-ALC.
De acero galvanizado con aleta simple.

100-ALC MANUAL

Modelo	Dimensiones
ALC100	100
ALC125	125
ALC150	150
ALC160	160
ALC200	200
ALC250	250
ALC315	315
ALC355	355
ALC400	400

100-ALC PARA MOTORIZAR

Modelo	Dimensiones
ALCT100	100
ALCT125	125
ALCT150	150
ALCT160	160
ALCT200	200
ALCT250	250
ALCT315	315
ALCT355	355
ALCT400	400

100-ALC

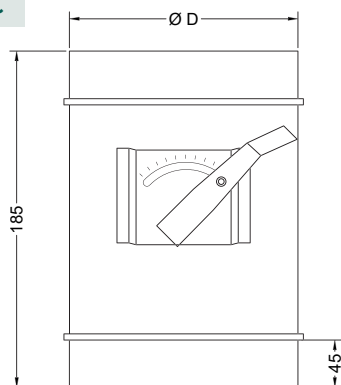

NOTA: Los modelos ALC y ALCT no se suministran con servomotor.

Incorpora junta interior de espuma para una mayor estanqueidad. Apertura mediante mando manual o compuerta motorizada. Disponible desde \varnothing 100 mm hasta \varnothing 400 mm.

